

Standard linear output current for high speed op amps such as EL8201 is typically 65mA. When more is required, the next available options provide around 200mA, but with a significant increase in cost and quiescent current. In these cases, it may be more cost efficient to configure a dual op amp to provide adequate output current.

## Circuit Description

A common solution is shown in Figure 1. The overall gain is  $1 + (R_2/R_1)$  and the output current is  $I_1 + I_2$ . This is only acceptable at low frequencies such as audio where the intrinsic delay of the op amp is negligible with respect to the wavelength of the input signal. At higher speeds, the output of  $A_1$  will drive the load significantly before  $A_2$  and the output drive will never reach twice the current.

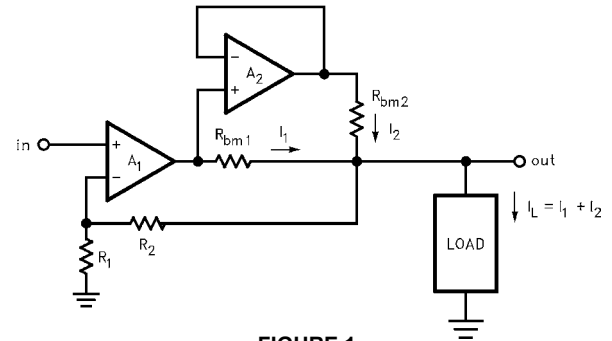

FIGURE 1.

In high frequency applications, the circuit in Figure 2 is preferable. Here the two op amps work in parallel. Since the dual package ensures the similar delay through each op amp, there will be no fighting at the output and twice the current will be delivered to the load. The overall gain is still  $1 + (R_2/R_1)$ .

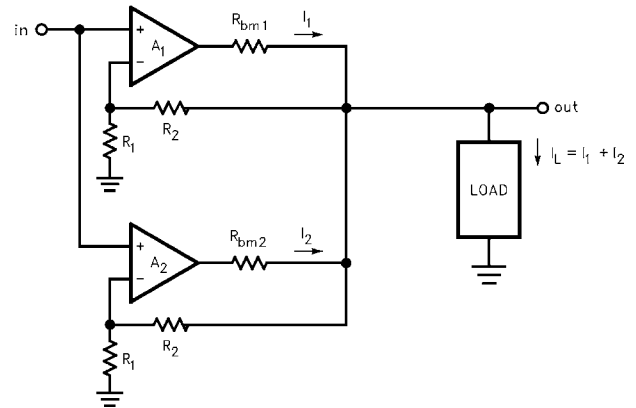

FIGURE 2.

Resistors  $R_{bm1}$  and  $R_{bm2}$  are back match resistors. When driving a transmission line,  $R_{bm1}$  and  $R_{bm2}$  should equal twice the characteristic impedance of the line to terminate it properly since they are driving it in parallel. If proper matching to a load is not necessary, then  $R_{bm1}$  and  $R_{bm2}$  simply isolate the outputs of  $A_1$  and  $A_2$ , limiting the current from any output offsets. For example, if the offset voltage was 10mV between the outputs of the two op amps, then  $R_{bm1} = R_{bm2} = 5\Omega$  would limit the offset current to 1mA, while allowing the maximum output voltage swing.

## Conclusion

A low cost option for increasing the effective output current drive of an op amp has been presented. Twice the output current is achieved with minimal addition of complexity.

Intersil Corporation reserves the right to make changes in circuit design, software and/or specifications at any time without notice. Accordingly, the reader is cautioned to verify that the Application Note or Technical Brief is current before proceeding.